

## FAA STC ST03209CH

### Installation of a Class 2 Electronic Flight Bag (EFB) System Provisions On Boeing 737 Series Aircraft

#### OVERVIEW

- » FAA STC ST03209CH

*Governs the installation of a Class 2 electronic flight bag (EFB) system provisions in accordance with Electronic Cable Specialists (ECS) Master Data List ECS-209828.*

#### YOUR NEEDS

Provides modernized EFB system mounting provisions for Boeing 737 series aircraft.

#### YOUR BENEFITS

The Class 2 EFB System provides flight crews the ability to interact with electronic maps, charts, and manuals in lieu of accessing standard paper documentation. System installation will reduce materials costs and aircraft weight without compromising ergonomic concerns.

#### STC AIRCRAFT EFFECTIVITY

- » Boeing 737-600/-700/-700C/-800/-900/-900ER series aircraft.

#### STC CONFIGURATIONS & LIMITATIONS

- » **Configuration 1:** Installation of Class 2 EFB system provisions for dual DU electrical power with crosstalk capabilities between the two units
- » **Configuration 2:** Installation of Class 2 EFB system provisions for dual DU and EFB-IU P1 connections only.
- » **Configuration 3:** Installation of Class 2 EFB system provisions for dual DU provisions and EFB-IU P1 and P2 connection.

*STC Limitations (All configurations): The equipment for which these provisions are intended has not been certified. Additional FAA approval is required for the installation of this equipment and must be evaluated to ensure satisfactory compliance with applicable airworthiness standards.*

#### PRODUCT DESCRIPTION

##### Installation Overview:

- » The Class 2 EFB System LRU provisions consist of an electronic flight bag interface unit (EFB-IU). The EFB-IU is not installed as part of Configuration 1.
- » Five circuit breakers (4-DU, 1-EFB-IU)
- » Two disconnect and power switch panels for removing power from the system
- » One mounting structure for holding the EFB-IU (Configurations 2 & 3 only)
- » Electrical wiring for power and signals to the DU disconnects and power switches
- » Electrical wiring for power and signals to EFB-IU (Configurations 2 & 3 only)

##### For this project, the EFB system will consist of the following:

- » **Display Unit (DU) Provisions (All Configurations)**  
The dual Display Units with interface cable will be approved under a separate FAA operational approval and are not included in this project. The provisions under this project include electrical power, discrete, and ethernet wiring. They are installed to power the DUs, provide crosstalk capabilities, and air/ground status. These units are not interfaced with any other aircraft systems.
- » **Electronic Flight Bag Interface Unit (EFB-IU) (Configurations 2 & 3 only)**  
The EFB-IU is mounted forward of the electronics bay on the left side outboard of the forward landing gear bay. It provides interfaces to the aircraft systems. It operates using the Linux operation system and meets the requirements for RTCA/DO-178B Level E determination. It also acts as a firewall to prevent unwanted access to critical aircraft systems.

# FAA STC ST03209CH

## Installation of a Class 2 Electronic Flight Bag (EFB) System Provisions On Boeing 737 Series Aircraft

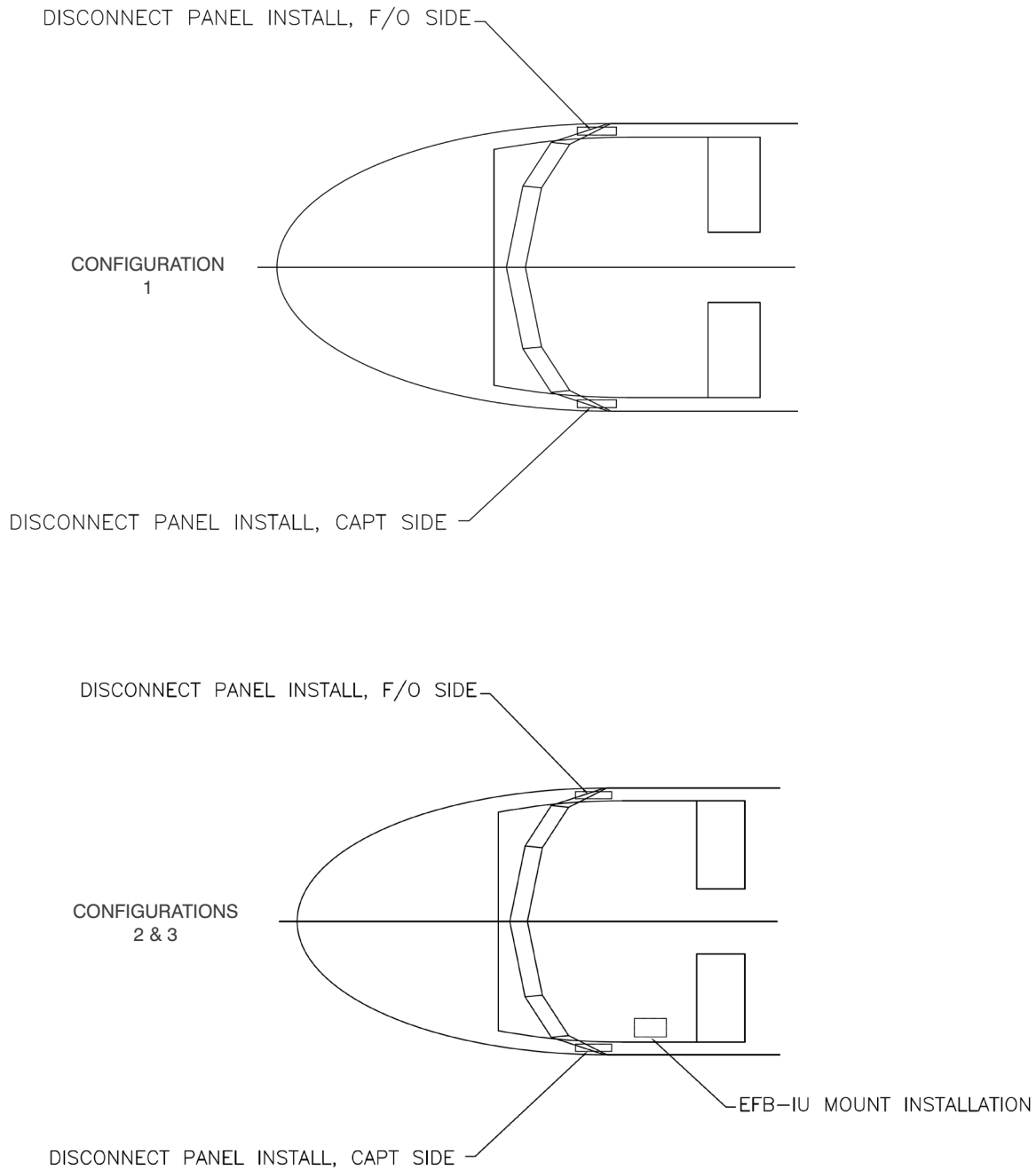

FIGURE 1: INSTALLATION OVERVIEW

## FAA STC ST03209CH

### Installation of a Class 2 Electronic Flight Bag (EFB) System Provisions On Boeing 737 Series Aircraft

#### MECHANICAL CHANGES (ALL CONFIGURATIONS)

- » The existing ash tray located on the captain's sidewall is removed and replaced with a disconnect panel assembly. The assembly consists of a power switch and a power/crosstalk interface connector for an EFB port.

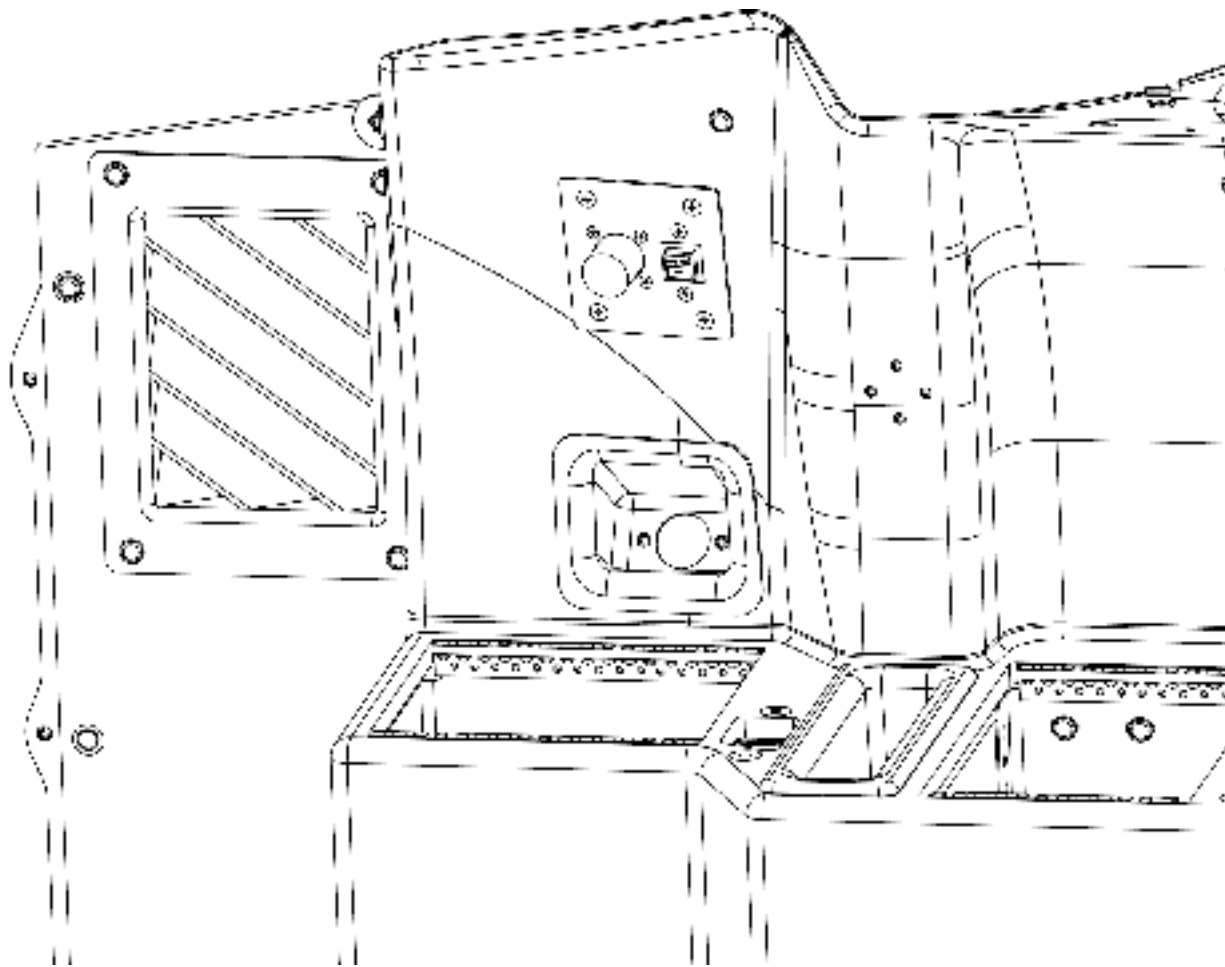

**FIGURE 2: EFB DISCONNECT PANEL CAPTAIN'S SIDE**  
(FIRST OFFICER'S SIDE IS A MIRROR IMAGE)

## FAA STC ST03209CH

### Installation of a Class 2 Electronic Flight Bag (EFB) System Provisions On Boeing 737 Series Aircraft

#### MECHANICAL CHANGES (CONFIGURATIONS 2 & 3 ONLY)

- » An EFB-IU mounting assembly is installed to the aircraft frames located behind the forward left side access panel of the nose wheel well.

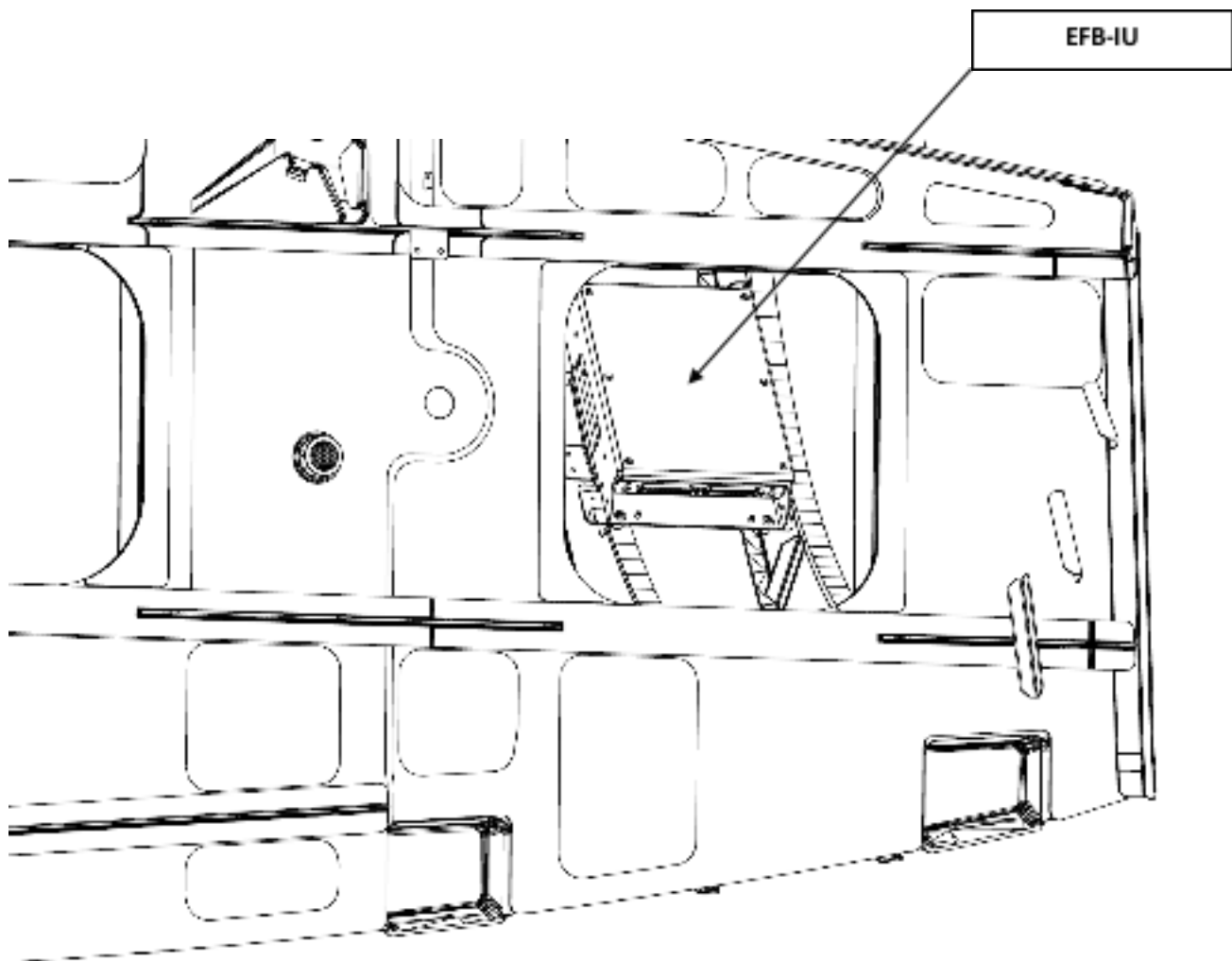

FIGURE 3: EFB-IU INSTALLATION  
CONFIGURATIONS 2 & 3

## FAA STC ST03209CH

### Installation of a Class 2 Electronic Flight Bag (EFB) System Provisions On Boeing 737 Series Aircraft

#### ELECTRICAL CHANGES

##### Configuration 1 (FIGURE 4):

- » Wiring to the proximity switch electronics unit (PSEU) for the forward entry door status discrete.
- » Wiring from each power switch/annunciator to the annunciator master dim and test circuit.
- » Circuit breakers and associated power wiring to each power switch/annunciator, each EFB disconnect panel, and circuit breaker provisions for the EFB-IU.
- » Ethernet crosstalk wiring between the captain and first officer EFB disconnect panels.

##### Configuration 2 (FIGURE 5):

- » Wiring to the proximity switch electronics unit (PSEU) for the forward entry door status discrete
- » Wiring from each power switch/annunciator to the annunciator master dim and test circuit.
- » Circuit breakers and associated power wiring to each power switch/annunciator, each EFB disconnect panel, and the EFB-IU.
- » Wiring to the air/ground relay for the aircraft status discrete.
- » Ethernet crosstalk wiring between the EFB-IU and the captain and first officer EFB disconnect panels.
- » EFB-IU aircraft interface wiring to the flight management computer-1 (FMC), air data inertial reference unit-L (ADIRU), and multi-mode receiver-1 (MMR). If a printer is installed, ethernet interface wiring may be connected from the EFB-IU to the printer.
- » EFB-IU provisions wiring to traffic alert and collision avoidance system (TCAS) and digital flight data acquisition unit (DFDAU).

##### Configuration 3 (FIGURE 6):

- » Wiring to the proximity switch electronics unit (PSEU) for the forward entry door status discrete
- » Wiring from each power switch/annunciator to the annunciator master dim and test circuit.
- » Circuit breakers and associated power wiring to each power switch/annunciator, each EFB disconnect panel, and the EFB-IU.
- » Wiring to the air/ground relay for the aircraft status discrete.
- » Ethernet crosstalk wiring between the EFB-IU and the captain and first officer EFB disconnect panels.
- » EFB-IU aircraft interface wiring to the flight management computer-1 (FMC), air data inertial reference unit-L (ADIRU), and multi-mode receiver-1 (MMR). If a printer is installed, ethernet interface wiring may be connected from the EFB-IU to the printer.
- » EFB-IU provisions wiring to traffic alert and collision avoidance system (TCAS) and digital flight data acquisition unit (DFDAU).

# FAA STC ST03209CH

## Installation of a Class 2 Electronic Flight Bag (EFB) System Provisions On Boeing 737 Series Aircraft

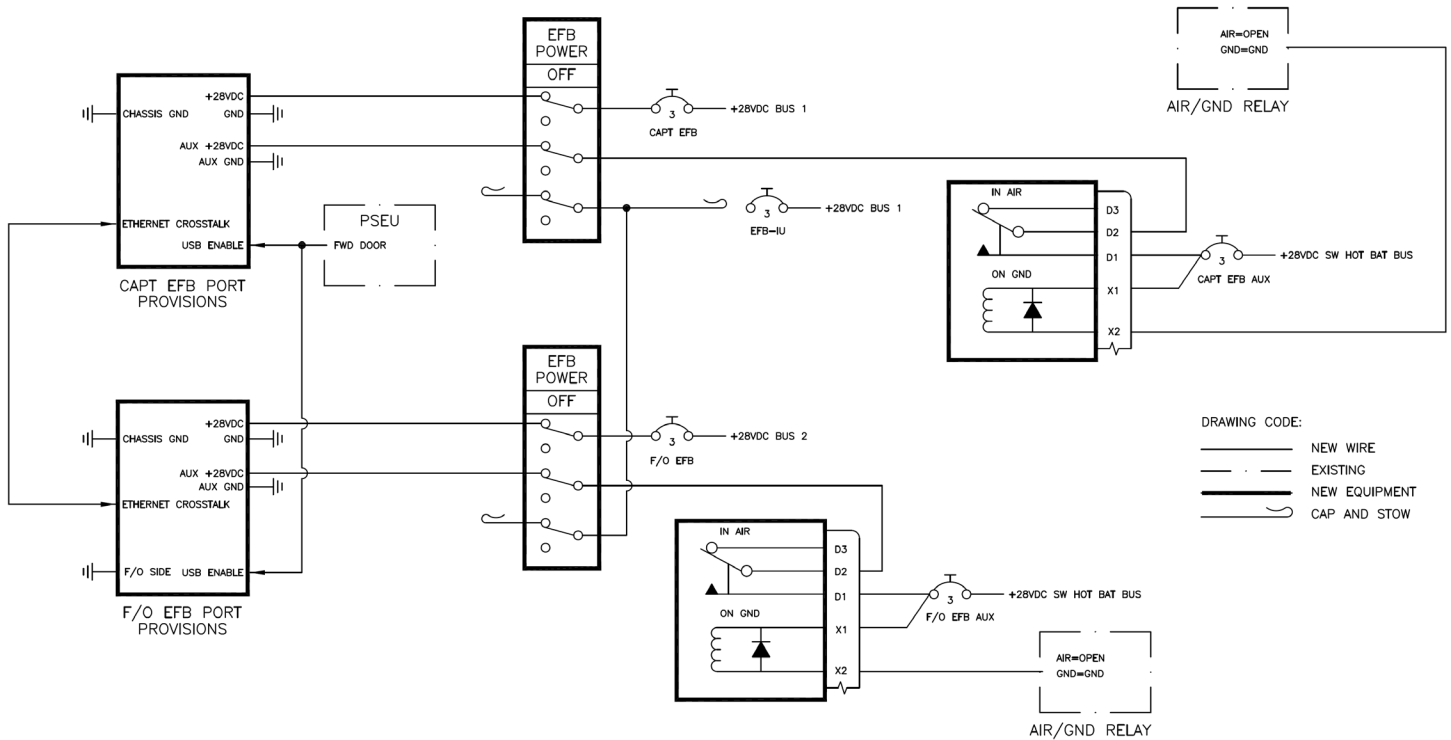

**FIGURE 4:**  
**SYSTEM BLOCK DIAGRAM (CONFIGURATION 1)**

# FAA STC ST03209CH

## Installation of a Class 2 Electronic Flight Bag (EFB) System Provisions On Boeing 737 Series Aircraft

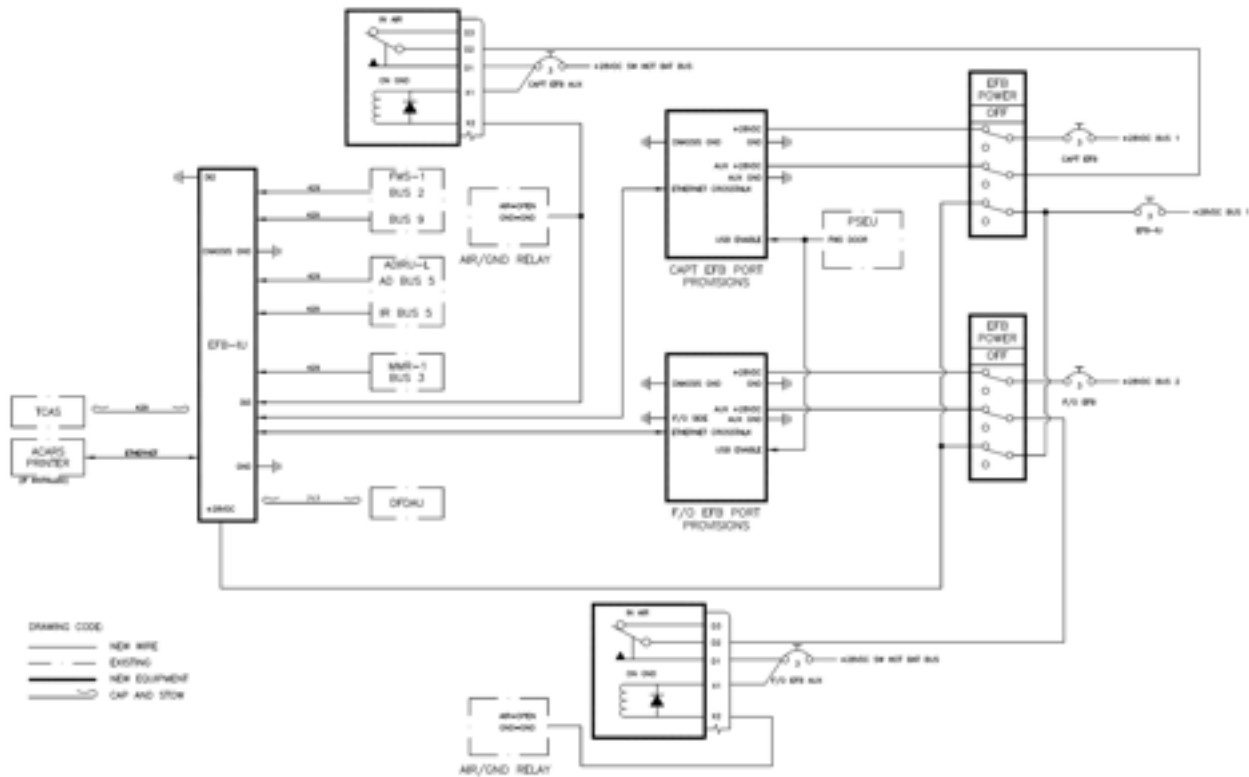

FIGURE 5:  
SYSTEM BLOCK DIAGRAM (CONFIGURATION 2)

# FAA STC ST03209CH

## Installation of a Class 2 Electronic Flight Bag (EFB) System Provisions On Boeing 737 Series Aircraft

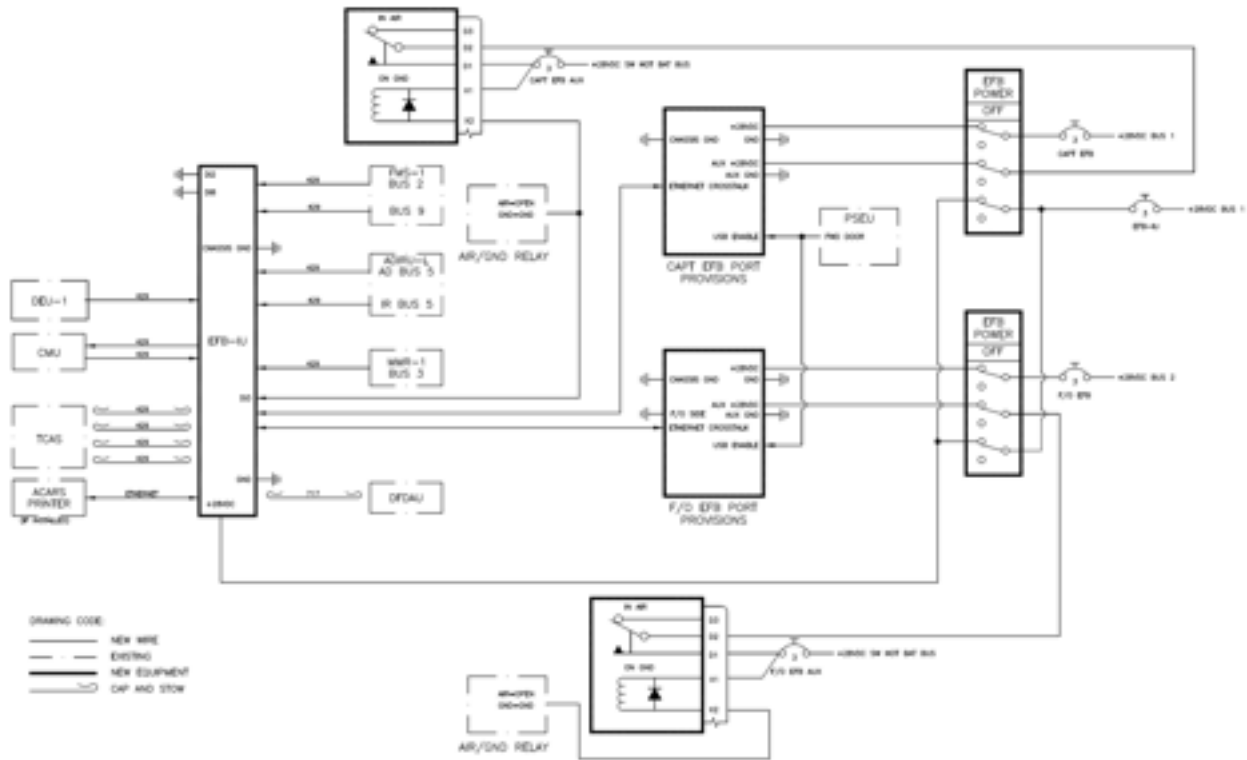

FIGURE 6:  
SYSTEM BLOCK DIAGRAM (CONFIGURATION 3)